

产品尺寸图 (DIMENSION)

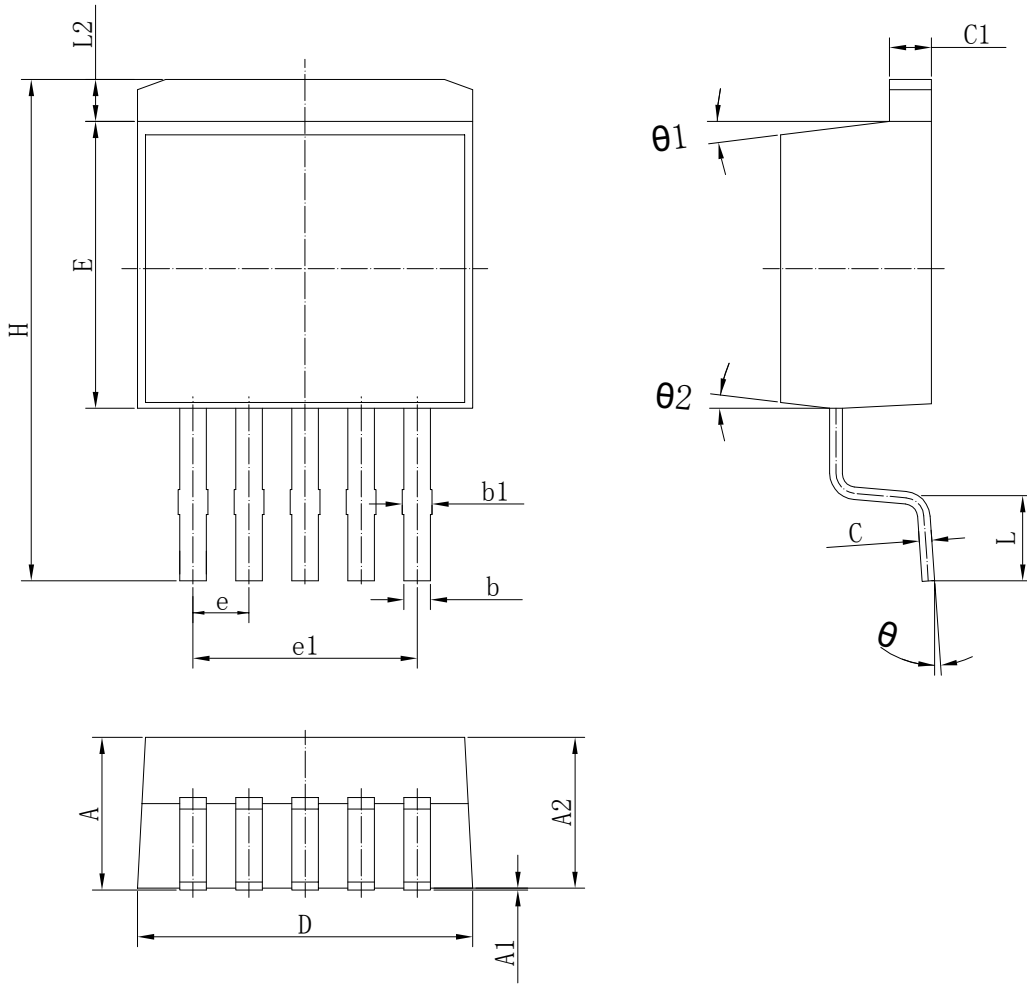

symbol	Dimensions In Millimeters			Dimensions In Inches		
	Min	Nom	Max	Min	Nom	Max
A	4.08	4.72	5.08	0.161	0.186	0.200
A1	0.02	0.15	0.25	0.001	0.006	0.010
A2	4.06	4.57	4.83	0.160	0.180	0.190
b	0.50	0.81	1.00	0.020	0.032	0.039
b1	1.14	1.27	1.40	0.044	0.050	0.055
C	0.33	0.40	0.47	0.013	0.016	0.019
C1	1.14	1.27	1.40	0.045	0.050	0.055
D	9.66	10.00	10.54	0.380	0.394	0.415
E	8.38	8.70	8.90	0.330	0.343	0.380
e	1.60	1.70	1.80	0.063	0.067	0.071
e1	6.70	6.80	6.90	0.264	0.268	0.272
H	14.60	15.25	15.88	0.575	0.598	0.625
L	2.24	2.55	2.84	0.088	0.100	0.112
L2	—	1.27	1.40	0.046	0.050	0.055
theta1	6°	7°	8°	6°	7°	8°
theta2	6°	7°	8°	6°	7°	8°
theta	0	—	8°	0	—	8°

FSMC

图名 NAME	T0-263-5		图号 DWG. NO.	DD0023	SH 1 OF 1
材质 MATERIAL	Cu		REV.	F	
单位 UNITS	mm [INCH]	核准 APPROVE	审核 CHECKED	制图 DRAWN	 第三角法
日期 DATE	2022.05.23				
比例 SCALE	N. T. S.				